

HOM115

Mini circuit breaker, Homeline, 15A, 1 pole, 120/240 VAC, 10 kA AIR, standard type, plug in mount

Product availability : Stock - Normally stocked in distribution facility



Main

Product	Miniature circuit-breaker
Range	Homeline
Current Rating	15 A
Certifications	UL Listed
Voltage Rating	120/240 V AC
Mounting Type	Plug-in
Number of Poles	1P
Short Circuit Current Rating	10 kA
Number of Spaces	1
Circuit Breaker Type	Standard
Ratings	HACR and Switching Duty rated
Electrical Connection	Clamp terminal for 2 cables
Wire Size	AWG 14...AWG 8 aluminium/copper)1 AWG 14...AWG 10 copper)2

Complementary

Tightening torque	35.40 lbf.in (4.0 N.m) 0.00...0.01 in ² (2.5...6 mm ²) AWG 14...AWG 8)
Height	3.13 in (79.50 mm)
Width	1 in (25.40 mm)
Depth	2.98 in (75.69 mm)

Environment

Ambient air temperature for operation	104 °F (40 °C)
---------------------------------------	----------------

* Price is "List Price" and may be subject to a trade discount – check with your local distributor or retailer for actual price.

Ordering and shipping details

Category	00046 - HOM/T 15-30A 1P; 15-60A 2P
Discount Schedule	DE3D
GTIN	00785901065203
Nbr. of units in pkg.	10
Package weight(Lbs)	0.29 lb(US) (0.13 kg)
Returnability	Yes
Country of origin	US

Packing Units

Unit Type of Package 1	PCE
Package 1 Height	1.00 in (2.54 cm)
Package 1 width	3.00 in (7.62 cm)
Package 1 Length	3.00 in (7.62 cm)
Unit Type of Package 2	BB1
Number of Units in Package 2	10
Package 2 Weight	2.84 lb(US) (1.288 kg)
Package 2 Height	3.60 in (9.144 cm)
Package 2 width	3.00 in (7.62 cm)
Package 2 Length	11.10 in (28.194 cm)
Unit Type of Package 3	CAR
Number of Units in Package 3	100
Package 3 Weight	29.15 lb(US) (13.222 kg)
Package 3 Height	11.10 in (28.194 cm)
Package 3 width	7.10 in (18.034 cm)
Package 3 Length	16.70 in (42.418 cm)

Offer Sustainability

Sustainable offer status	Green Premium product
REACH Regulation	REACH Declaration
REACH free of SVHC	Yes
EU RoHS Directive	Compliant EU RoHS Declaration
Toxic heavy metal free	Yes
Mercury free	Yes
RoHS exemption information	Yes
China RoHS Regulation	China RoHS declaration Pro-active China RoHS declaration (out of China RoHS legal scope)
Environmental Disclosure	Product Environmental Profile

Contractual warranty

Warranty	Lifetime
----------	----------

Dimensions

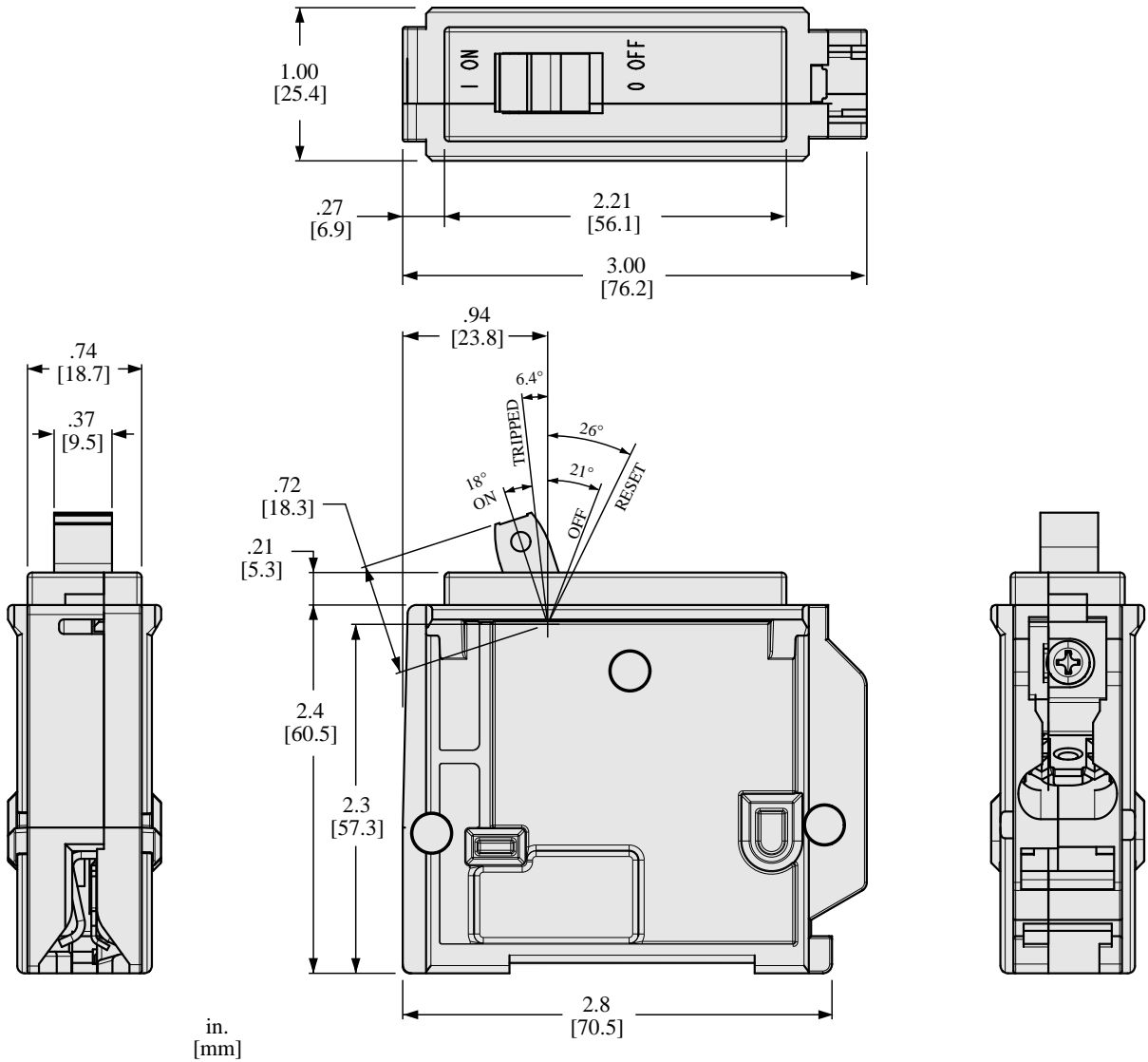

All dimensions are approximate. Also refer to technical drawings and documentation.